

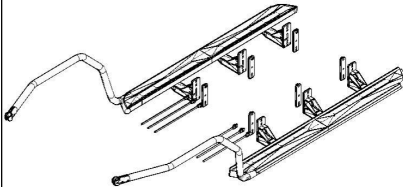









## Universal Pickup Side Bar + Guardrail

Product number	Drawing Numbers	Product Image	Product accessories	Product accessories pictures	Remark
		    <p>More clear pictures please Scan the QR code on the right</p>	Pair of side bars 47 Sealing -- 2		
			Pair of pattern panels Stainless steel mushroom head M6X 16--28 sets (does not match flat spring pad)		
			Six brackets (regardless of left and right)		
			Bracket accessories --6 8.8 grade M12X130--6 sets (with large flat pad) 8.8 grade M12X130--6 pieces (with large flat pad, spring pad)		
			Nut plate -- 6 8.8 M12X35--12 (Trim spring washers)		
			Wire Nut Plate--6pcs 8.8 M12X35--6 pieces (Trim spring washers)		
			Pair of side bar corners 8.8 grade M8X35--4 sets 47 Sealing -- 2		According to the order
			A pair of guards 8.8 grade M8X35--4 sets 47 Sealing -- 2		According to the order
			Bending connection mold--4 Stainless steel M8X70--6 sets (with lock nut)		According to the order

*If there are any changes, we will notify you*

# (Assembly diagram)

1. (Refer to the figure below to install the bracket.)

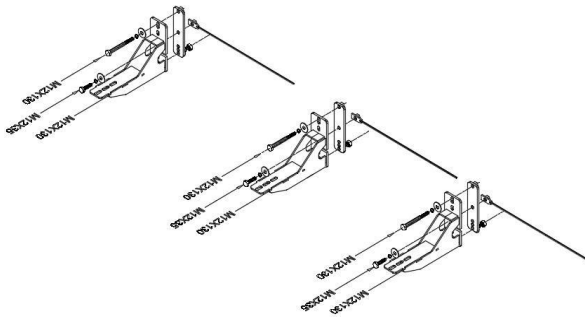

2. (Refer to the figure below to install the bracket.)

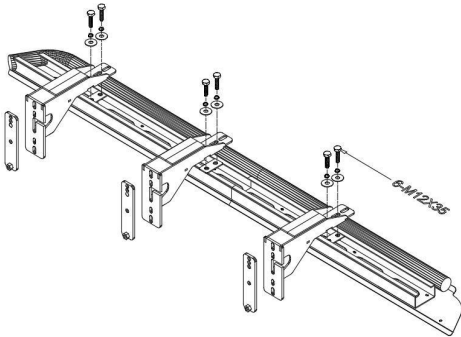

3. (Refer to the figure below to install the side bar corners (note that only one corner or side guardrail can be installed).)

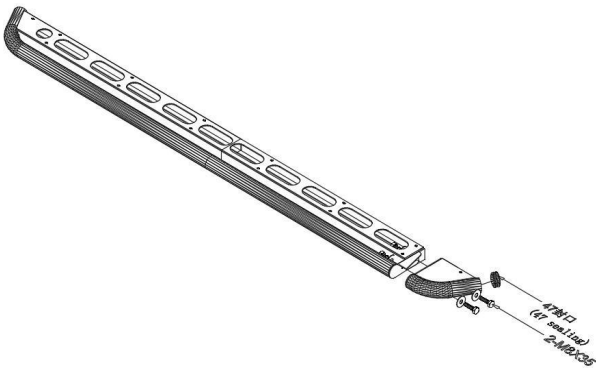

4. (Refer to the figure below to install the side guardrail (note that only one corner or side guardrail can be installed).)



5. (Refer to the figure below to install the side bar panel.)

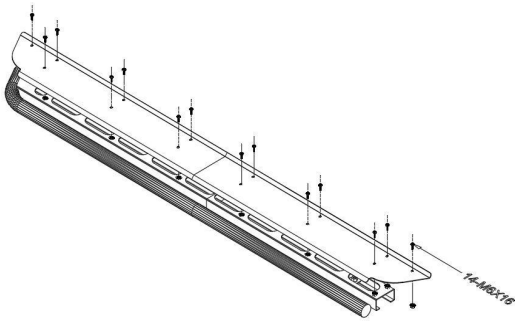

6. (Refer to the figure below to connect the side guardrail and the front bumper body (Note that after matching the appropriate position, mark and punch holes on the 47 round tube).)

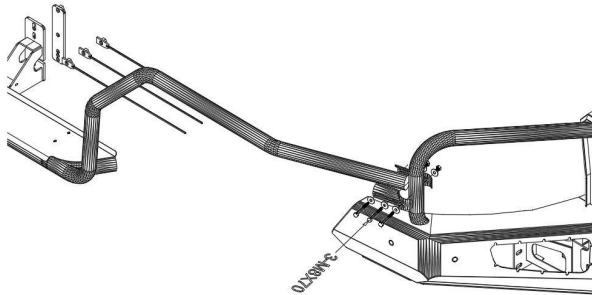

7. (Check whether the lever body is installed in place, and tighten all the screws to complete the installation.)