

Fitment Instruction: P Series nudge bar

Visual / Graphic Illustration

Note: remove dust cover (Figure A) before starting fitment .

Fig 1

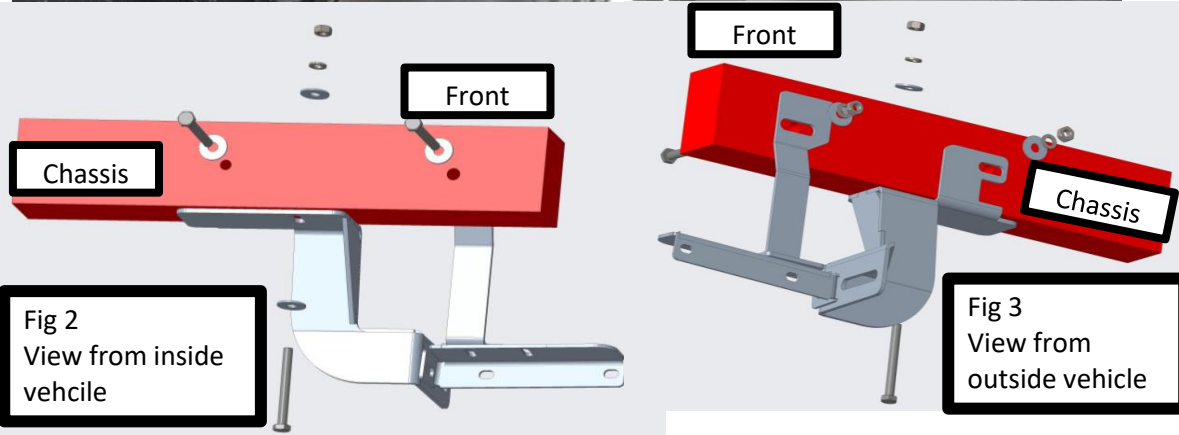

Step No.

Description/Method

1

Place the Passenger's side Mounting Bracket (L) directly behind the tow eye as seen in Fig 1. Using the bolts supplied loosely secure it onto the chassis - see the simplified 3D model below to assist

2

Insert the Fasteners as shown in Figure 2 and 3. Refer to STEP 3 for the fastner breakdown. Do not tighten fully until the very end.

Fitment Instruction: P Series nudge bar

Visual / Graphic Illustration

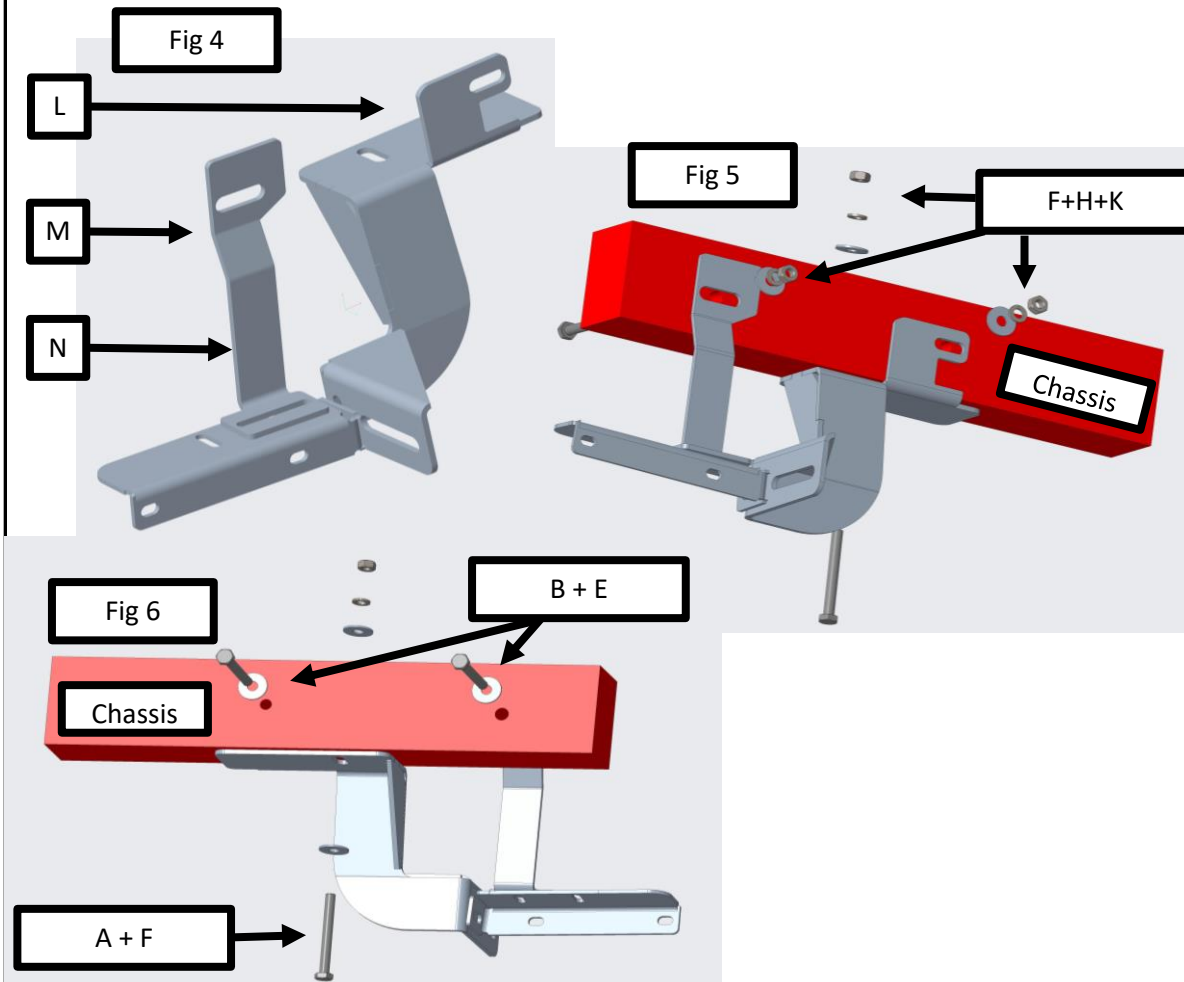

Step No.

Description/Method

Step 3

Refer to Fig 4 for the assembly of brackets L, M and N

Step 4

Insert Fasteners as shown in Figure 5 and 6 Do not tighten fully.

Fitment Instruction: P Series nudge bar

Visual / Graphic Illustration

Step No.

Description/Method

Fig 7

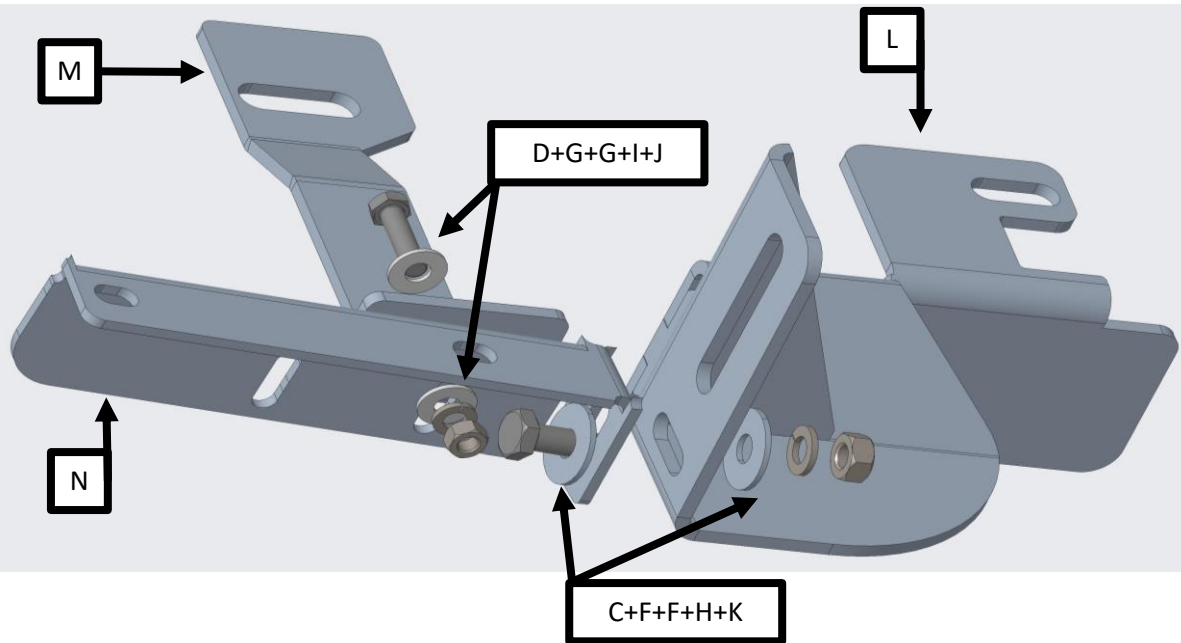

Step 5

Repeat steps 1 to 4 on the driver's side of the vehicle.

Fitment Instruction: P Series nudge bar

Visual / Graphic Illustration

Step No.

Description/Method

Fig 8

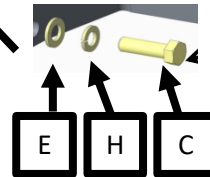

Step 7

Place the Nudge Bar against the Chassis Mount Bracket and insert fasteners as shown in Fig 8. Do not tighten fully.

Final step

Make sure bar is centralised and tighten all fasteners to specified torque. M8= 22Nm , M10= 42Nm , M6= 9Nm.

