

Installation Instruction for Roller Lid Cover









(Stainless Steel Canister)

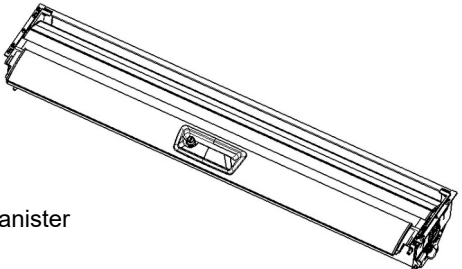
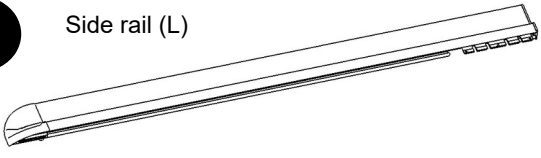
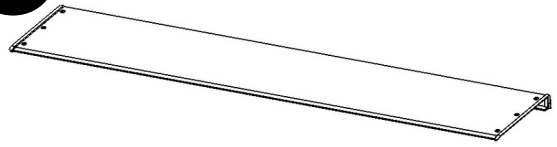
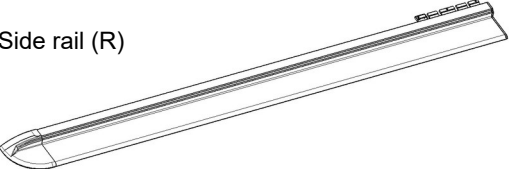
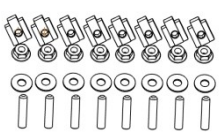

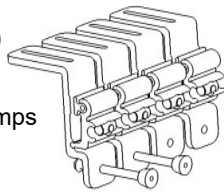
Before Installation

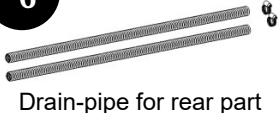
Please read the instruction completely for easy installation, which will also help you to avoid scratches or other potential damages to your appealing car.
 Please periodically check and retighten all the hardware and clean the investment for a refresh look.
 The figures here are for reference only and may have differences with the actual product you received, however they share the same assembly way.

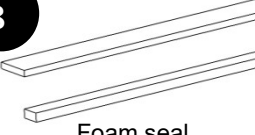
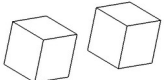
PART LIST

<div style="text-align: center;">A</div>  <p style="text-align: center;">Canister</p>	<div style="text-align: center;">B</div> <p style="text-align: center;">Side rail (L)</p> 		
<div style="text-align: center;">D</div>  <p style="text-align: center;">Cover plate (For canister)</p>	<div style="text-align: center;">C</div> <p style="text-align: center;">Side rail (R)</p> 		
<div style="text-align: center;">1</div>  <p style="text-align: center;">Accessories for brackets</p>	<div style="text-align: center;">2</div>  <p style="text-align: center;">Bracket for tailgate lock</p>	<div style="text-align: center;">3</div>  <p style="text-align: center;">Clamps</p>	<div style="text-align: center;">4</div>  <p style="text-align: center;">Bolts for side rails</p>
<div style="text-align: center;">5</div>  <p style="text-align: center;">Accessories for cover plate</p>	<div style="text-align: center;">6</div>  <p style="text-align: center;">Drain-pipe for rear part</p>	<div style="text-align: center;">7</div>  <p style="text-align: center;">Drain-pipe for canister</p>	<div style="text-align: center;">8</div>  <p style="text-align: center;">Foam seal</p>
<div style="text-align: center;">9</div>  <p style="text-align: center;">Positioning rubber foam (Tailgate)</p>	<div style="text-align: center;">10</div>  <p style="text-align: center;">L-shaped brackets</p>	<div style="text-align: center;">11</div>  <p style="text-align: center;">Sport bar bracket & fitting kit</p>	



Tools and materials needed

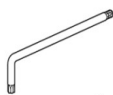

T15, T30

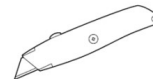

Installation Steps

1. Cleaning the trunk and margin by water X, dismantling the other unnecessary part for clean and tidy.

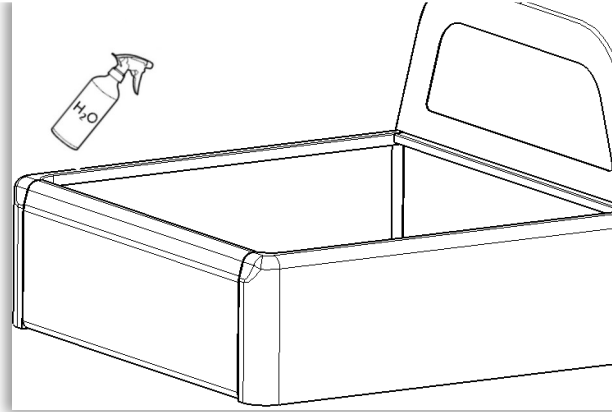

2. Install side rails \ on canister with .

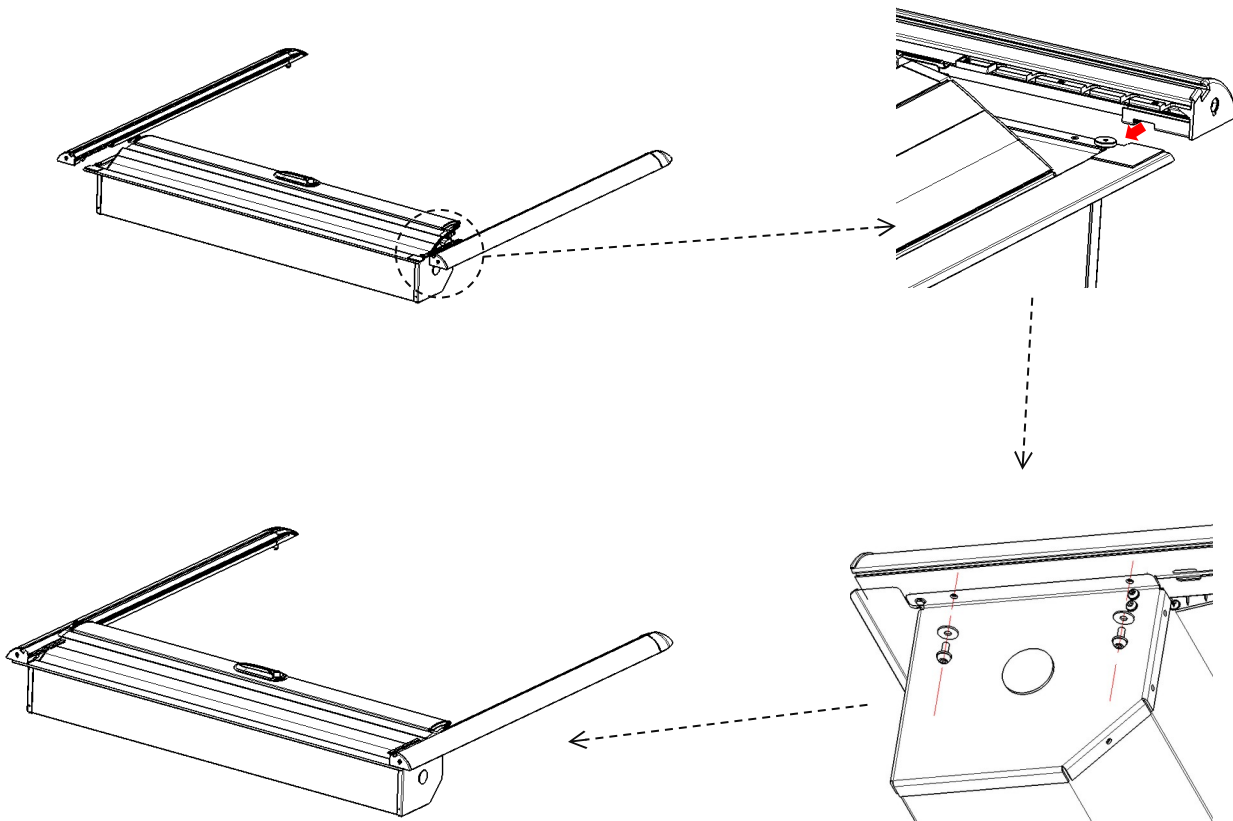

3. Install plate on the side rails with .

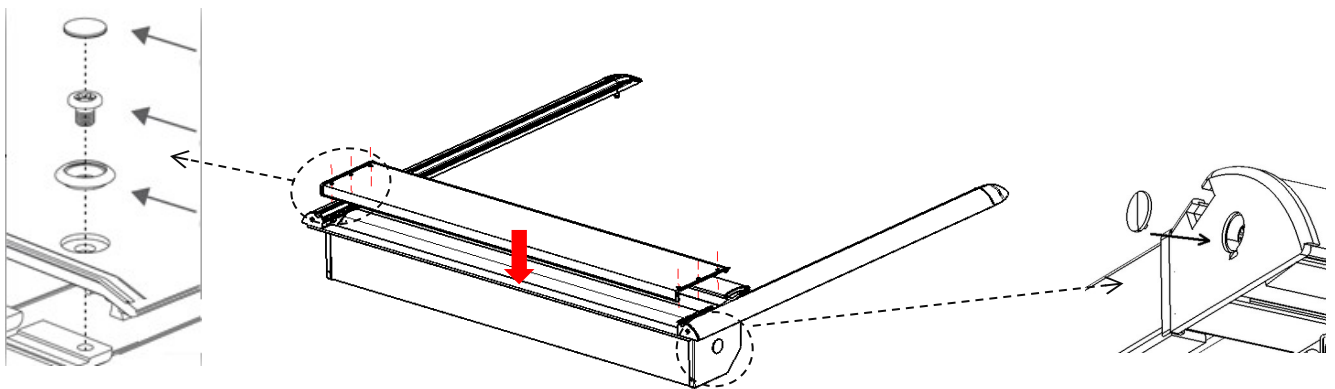

4. Find the two holes on the front of the truck bed, and then install the drain ring on it. Both sides should be same. Install the bulkhead seal and trim it at the corner part to match the side rails.

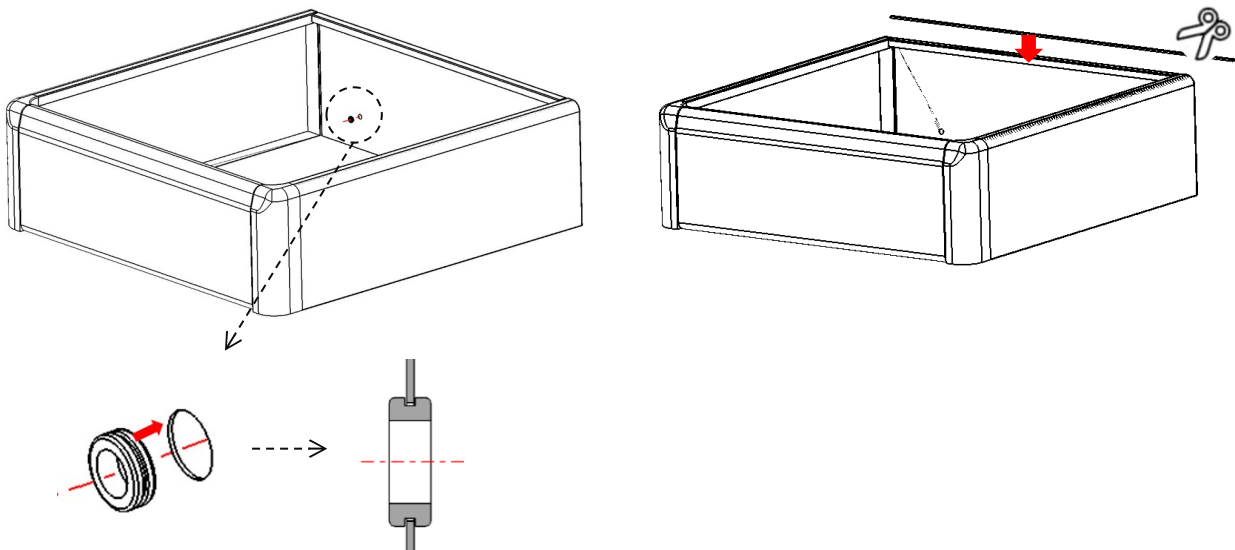

5. Put the roller lid cover on the truck bed.

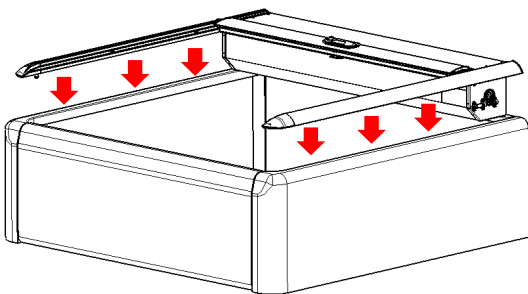

6. Put the rubber foam on the tailgate, as the photo shows above. Close the roller lid and pull it backwards until it touch the rubber foam.

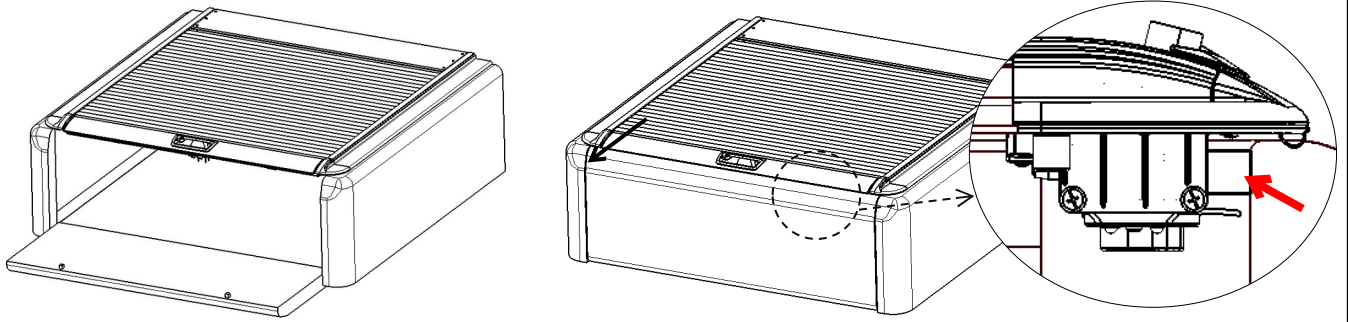

7 . Open the roller lid and put the standard bar to adjust the width between two side rails. Distance between the side rails should be same from front to rear part.

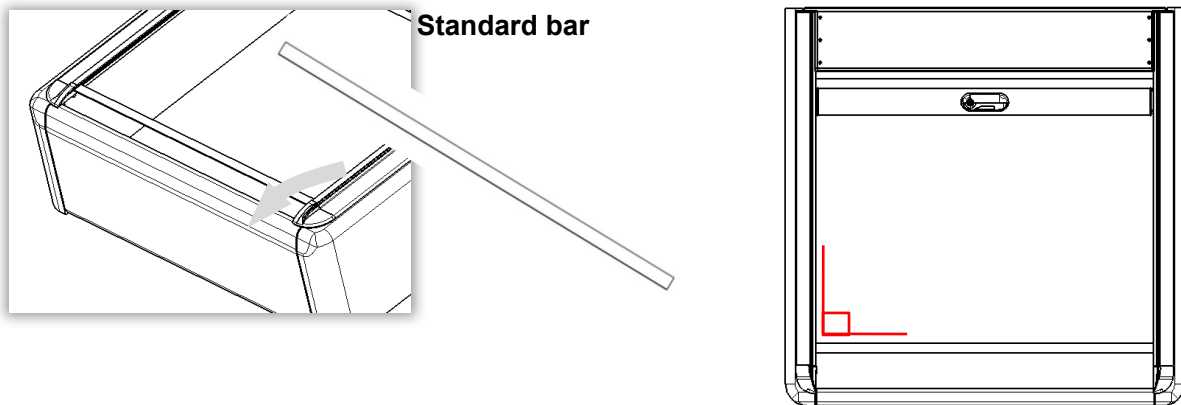

8. As the figure shows, M6 bolt screwed into M6 square nut. Then put the bolts into the side rails, 4 pieces on each side.

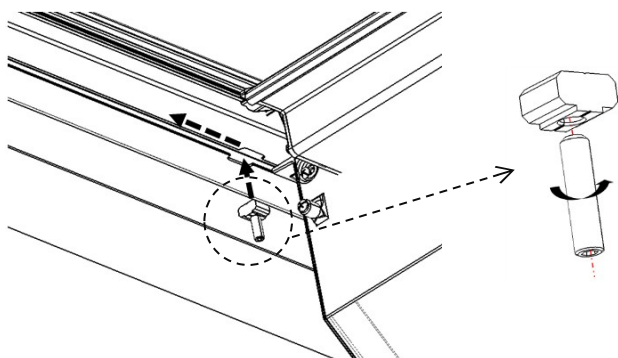

9. Install clamps & L-shaped brackets with extra-long bolt should be installed at the front side. (Close to CAB)

L-shaped bracket would be fastened on the truck bed original holes.

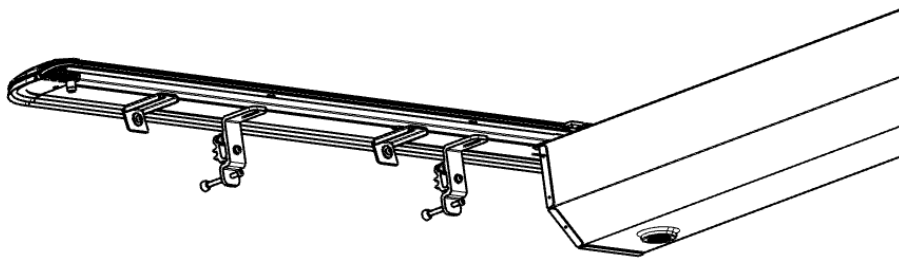
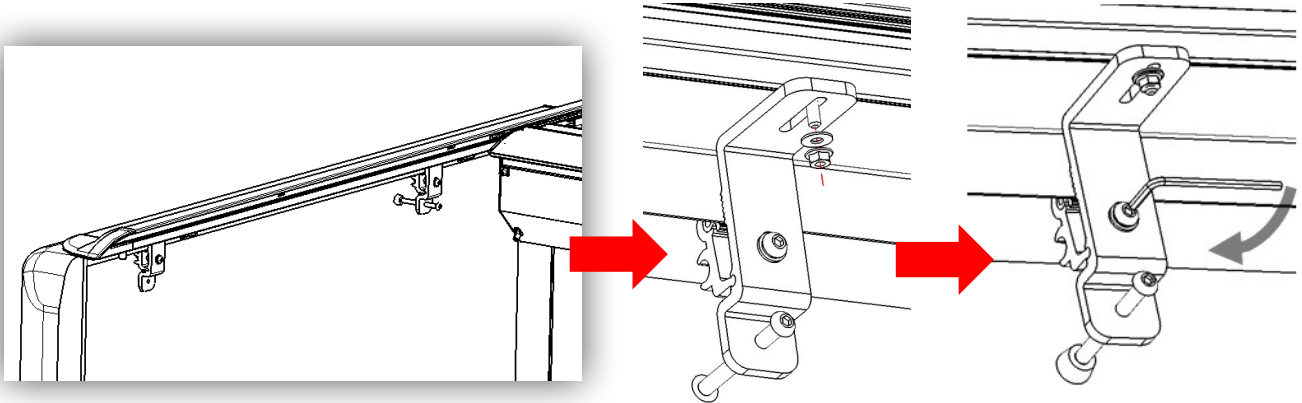

10. Fasten the long bolt below if needed.

Notice: Fasten the long bolt below until the side rail reach horizontal status.

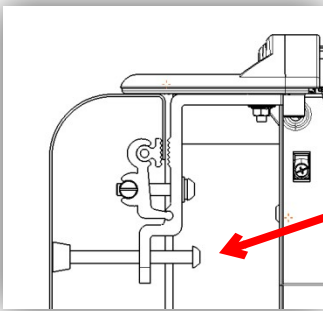

Let side rail keep horizontal status

11. Install the drain-pipe at the rear part of the tracks. (Both sides should be same)

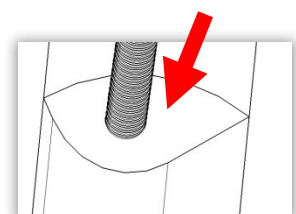
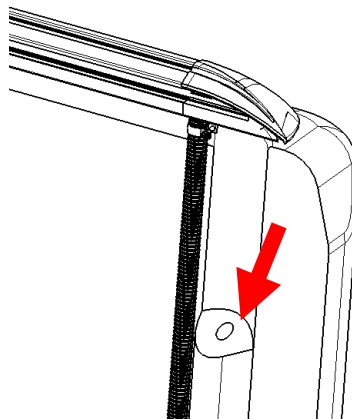
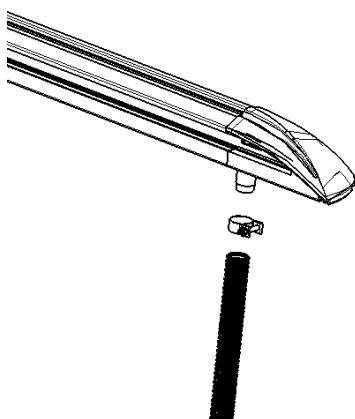

12. Install the drain-pipes on canister, threading them through the front holes

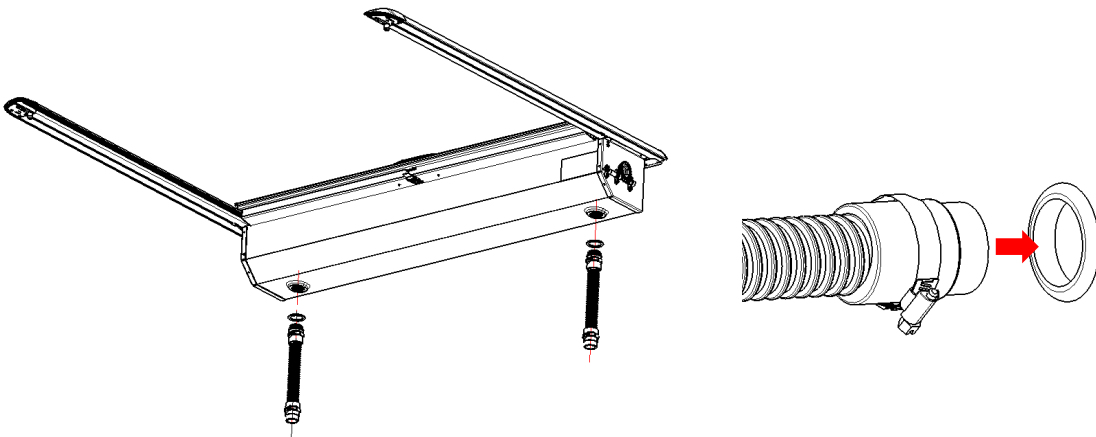

13. As the figure shows, install on tailgate door. Instruction details could be referring to the last page.

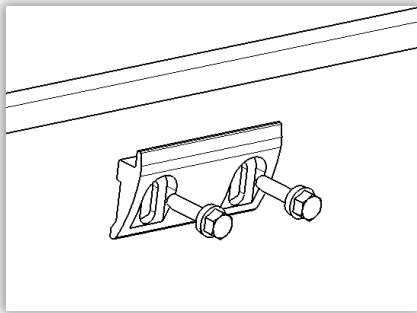

14. Original sport bar installation, same as the picture shows below.

Slide in the T-stone into side rail top channel. Install the sport bar bracket same as the picture shows below

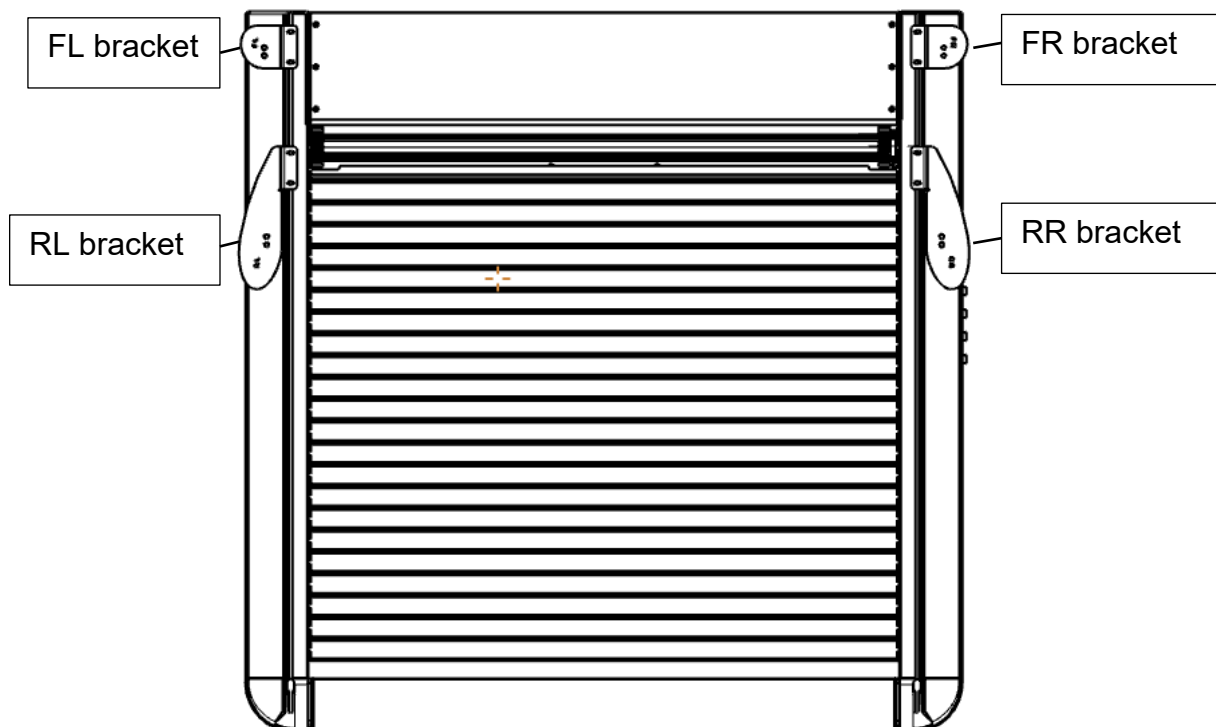

15. If the roller shutter do not runs smoothly, you can follow below steps: (as the picture shows)

a. Put some lubricating oil on the track.

b. Adjust the spring.

(Notice: These 2 steps should be done every 3 months; also you can do it if needed.)

